



## Linkbelt Series Installation Guide

Any questions please call 1-800-257-1243

\*Trademarks are the property of specified companies

### Installation Instructions

Remove Lip Seal and Retainer Ring to be replaced with CinchDrive Cartridge Seal.

1. Tap purge hole for 1/8" pipe plug into Housing.  
\*Center of purge hole should be 1.32" from bottom. See dimensions.
2. Press fit (.001) CinchDrive Cartridge Seal into the recess with purge holes going in first as pictured below.  
\*Purge holes in Cartridge do not need to line up directly with purge port of the housing.  
The groove in the cartridge will allow flow to the purge holes.  
\*Use only mild soapy water to lubricate cartridge if necessary when sliding onto shaft.

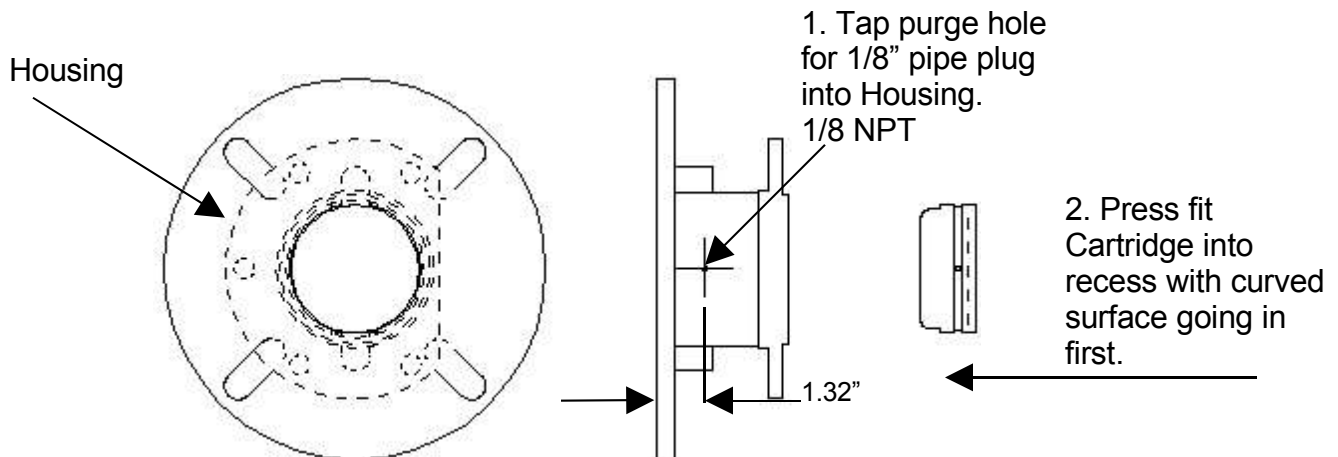

3. Check Adaptor Plate flange faces.  
Faces must be 32 RMS finish and within OEM design standards to mount flush and square to the bulkhead.
4. Tighten mounting hardware to Manufacturers recommended torque settings.  
\*Housing must be **perpendicular - normal** to the shaft.  
Check for equal spacing around the shaft and the ID of the seal.  
\*Alignment of housing to shaft cannot exceed 2°.
5. Purge seal before operating.  
\*Operating temperature range: - 50°F / 45.55°C to + 500°F / 260°C  
\*Above 200° must use air purge.

### Purge options available:

Purge option 1: Air Purge using an Air Regulator.

Airflow to be set 5 to 8 psi above vessel pressure.

Purge option 2: Silicone Grease Purge.

Purge cartridge with silicone grease until the excess seeps out.